

I WAS A TEENAGE LUDDITE



J (F.C.)-JONES

J (F.C.)-Jones is a poet and essayist. His work has appeared in journals such as *Freedom* (est. 1886), and with *The Anarchist Library*. He lives in Prague, Czech Republic.

FORGED BOOKS print dangerous book(let)s. Our titles include *Affirming the Open* by Julian Langer, *Summerisle Versus Civilisation* by J. Fraser, and *Monster Megaprojects are Consuming the World!* by Alexander Dunlap.

Dedicated to Ned Ludd

Two books are on the black desk of my teenage bedroom. At fifteen, I pick them up, hold them, put them back down. George Orwell's *1984*, of 1949 and Aldous Huxley's *Brave New World*, of 1932. A third one is invisible. I never owned it, reading it on the internet in secret, despite this technological irony. It was a treatise by one Theodore John Kaczynski, titled *Industrial Society and its Future* first published in the Washington Post in 1995. It demanded the total dismantling of the mass-industrial world. On first publication, it caused no small amount of controversy. It is better known as the Unabomber Manifesto.

Eight years prior to the publication of Kaczynski's manifesto, a spurious (and now infamous) profile sketch had been drawn up for the FBI: a moustached man in aviators and a paisley bandana, hood drawn over his head. This image itself is an icon, even if it isn't as ubiquitous as Che. In some sense, as with Guevara, this has anaesthetised its seriousness. Three people were killed and twenty-three more injured in a series of bombings, commencing in 1978 and terminating in 1995, targeting figures across North America who represented modern industrial progress. From a professor at Northwestern University, to American Airlines Flight 444. From computer store managers, to public relations executives at Exxon.

Being in a minority, even in a minority of one, did not make you mad. There was truth and there was

untruth, and if you clung to the truth even against the whole world, you were not mad.

1984 presaged my feelings of being sane against the world, that a minority of one is not by definition mad. It only required a truth to become valid, to be authentic. It needed a rhetorical counterpart, a figurehead. An icon. Prior to 1971, the year of his retreat to a cabin in the woods near Lincoln, Montana, Kaczynski had been a highly promising mathematician, a high-school overachiever, and a Harvard alumni. These aspects of his life are not infrequently held up as justifications of his intelligence, and even the logic of his methods, though genius is rarely total or unmarred, nor an excuse for a person's moral life. Ultimately, he graduated less impressively than expected, with a 3.12 GPA, a low B-grade. It would take decades before he would write *Industrial Society and its Future*.

3. If the system breaks down the consequences will still be very painful. But the bigger the system grows the more disastrous the results of its breakdown will be, so if it is to break down it had best break down sooner rather than later.

As I continued to read Kaczynski's manifesto, I began involving myself more and more in his ideas. My English teacher, Mrs. G, who was my school-friend's mother, had offered me a choice of books reserved for enthusiastic readers. Over Sophocles's *Oedipus Rex*, I chose a work titled,

Utopian Dreams, by Tobias Jones, published in 2007. I read it with continual disappointment.

Freedom isn't morally neutral; the emancipation it offers is a means, not an end in itself.

Jones offered glimpses of aphoristic insight, on the moral non-neutrality of freedom, on the nature of the anti-establishmentarian ideal. But when Kaczynski's text had presented me with the facts of retreating from society, with the reality of ideological violence, held against the manifesto, Jones's work could only seem cloying. At that time I saw it (as in Kaczynski's somewhat Freudian analysis) to be a surrogate activity, an exercise of comfortable dissatisfaction.

38. But not every leisured aristocrat becomes bored and demoralized. For example, the emperor Hirohito, instead of sinking into decadent hedonism, devoted himself to marine biology, a field in which he became distinguished. When people do not have to exert themselves to satisfy their physical needs they often set up artificial goals for themselves. In many cases they then pursue these goals with the same energy and emotional involvement that they otherwise would have put into the search for physical necessities.

Where *Utopian Dreams* failed me, it no less succeeded in exploring communes I hadn't imagined existed, from Damanhur on the spurs of the Alps, to the Catholic microcosm of Nomadelfia in Tuscany, with their own idiosyncrasies regarding living off-the-grid. Its failure was circumstantial: I was searching not for a journalist, but a prophet.

162. The system is currently engaged in a desperate struggle to overcome certain problems that threaten its survival, among which the problems of human behavior are the most important. If the system succeeds in acquiring sufficient control over human behavior quickly enough, it will probably survive. Otherwise it will break down. We think the issue will most likely be resolved within the next several decades, say 40 to 100 years.

Mounting declamations of crises, of eras of catastrophe, ecological or otherwise, were already becoming the norm some twenty years after the manifesto was published, making Kaczynski's doomsday predictions seem considerably less shocking in the second decade of the twenty-first-century, though ruefully prescient.

165. But suppose on the other hand that the stresses of the coming decades prove to be too much for the system. If the system breaks down there may be a period of chaos, a "time of troubles" such as those

that history has recorded at various epochs in the past. It is impossible to predict what would emerge from such a time of troubles, but at any rate the human race would be given a new chance. The greatest danger is that industrial society may begin to reconstitute itself within the first few years after the breakdown. Certainly there will be many people (powerhungry types especially) who will be anxious to get the factories running again.

Ted Kaczynski was sentenced to serve eight consecutive life sentences without parole in the supermax ADX prison in Florence, Colorado. The image of some Ezekiel imprisoned, condemned to watch the unfolding of his prophecies that went ignored. A Cassandra. Is this a romantic impression? For years I considered mailing my thoughts to the Unabomber, 04475-046, at his prison address. I wrote frantic essays on the nature of the system (trying to comprehend what this system was), analyses of his manifesto. None of them ever went further than the pages of a teenage notebook.

Then I was almost twenty. At night I would go out alone, dressed all in black, my hair shaved into a mohawk, armed with a can of spray-paint. Where before I had listened to the generic of stadium rock, loved Chopin, folk, and played in several groups in Withington and Chorlton, I began listening to British anarcho-punk recordings. Crass. Rudimentary Peni. Conflict. The 1986 track, *This is The A.L.F.*

Mechanised slaughter and chemical testing. Logically, Neoluddism must extend to animal rights.

It's possible to do things alone
Slash tires, glue up locks
Butchers, burger bars, the furriers
Smash windows, bankrupt the lot
Throw paint over shops and houses
Paint stripper works great on cars
Chewing gum sticks well to fur coats
A seized engine just won't start

I studded my clothes, tore them, became a vegetarian, shouted awful music in a band, drank heavily and began working for a painter-decorator. From young, white and strange, I had gone to strange, angry and white: a deadly cul-de-sac of a destination. I spent day-long hours in Stockport Central Library, which being in the Greater Manchester area, was stocked with all sorts of studies, archives and minutiae on the machine-smashers movement of the nineteenth-century.

In justice to humanity We think it our Born Duty to
give you this notice
That is if you do Not Cause those Dressing Machines
to be Remov'd

Within the Bounds of Seven Days ..., your factory and
all that it

Contains Will and Shall Surely Be Set on Fire ...

signed General Justice

General Justice was represented by General Ludd's wives in 1812, two men who dressed as women, though whether they would have identified as the opposite gender, isn't clear. And Kaczynski too, prior to his 1971 retreat to the woodland cabin, had been tormented by his decision to transition to female, going so far as to be granted a consultation on his psychiatrist's orders, before backing out of the waiting room in self-disgust. The connection, if tenuous, is a peculiar one: the desire to transgress gender in the case of General Justice, may have been a form of absurdism and disguise. It is difficult, but not impossible, to argue that, for Kaczynski, the case would have been the same.

Heading their 1812 insurgency in March, General Ludd's Wives led a crowd of handloom weavers into an attack on the residence and factory of one Mr. Goodair, a Stockport industrialist. His wife and children took shelter in the Buckley Arms, an inn not far from the factory, where she composed a letter to her husband, reporting the events.

This morning, about 9 o'clock, the people began to assemble in great numbers. They halted at our large gates, (at Edgeley), and remained there for nearly an

hour, calling to us at intervals to open our windows, and throwing stones in order to compel us to comply with their wishes. Finding neither of any avail, they proceeded towards this town, their numbers increasing as they proceeded along. Instead of entering by the usual road, they visited several houses and factories, where they broke all before them.

Causing destruction and unrest, the Luddites had moved onwards to the residences, mills and warehouses of Peter Marsland, Hindley & Bradshaw, and the factory of William Radcliffe, one of the first manufacturers of the power-loom. Almost killed by one such mob, Mr. Garside (a mill owner) was only spared when some of the crowd held back the other attackers in their ranks. *The Manchester Gazette* later reported on the attack on the Radcliffe warehouse.

On Monday afternoon a large body, not less than 2,000, commenced an attack, on the discharge of a pistol, which appeared to have been the signal; volleys of stones were thrown, and the windows smashed to atoms; the internal part of the building being guarded, a musket was discharged in the hope of intimidating and dispersing the assailants. In a very short time the effects were too shockingly seen in the death of three, and it is said, about ten wounded.

There were women among the Luddites in those early years, not only those men who presented themselves in female dress. Famously, at the steam-driven Westhoughton Cotton Mill, near Bolton, the young Molyneux sisters egged-on the machine-smashers, also in 1812, as was later described in court hearings.

About fifty assembled ... they smashed through the gates and started to break windows in the mill, led by two young women, Mary Molyneux, 19, and her sister Lydia, 15, who were seen, according to court papers, “with Muck Hooks and coal Picks in their hands breaking the windows of the building”... shouting “Now Lads” to encourage the men on. With the windows broken, men took straw from the stables and set a series of fires inside: “The whole of the Building,” wrote the Annual Register correspondent, “with its valuable machinery, cambrics, &c, were entirely destroyed.”

The first Luddite movement appears to have developed in Nottinghamshire, the initial attacks commencing in November, 1811. New manufacturing methods, particularly steam-powered looms, continued to decimate a commercial populace formerly dominated by artisanal guilds and craftsmen. The traditions of skilled occupations were rendered obsolete by factory-production, where non-apprenticed youths used wide-frames to make stockings and hosiery of a cheaper, inferior quality. Hailing from

Nottinghamshire, many Luddites would have been quick to play on the folklore of their past.

Chant no more your old rhymes about bold Robin Hood,

His feats I but little admire,

I will sing the Achievements of General Ludd

Now the Hero of Nottinghamshire!

Luddite as a term was taken from one young Ned Ludd (later mythologised as General Ludd) of Anstey, near Leicester, who as far back as 1779, had allegedly smashed two knitting-frames to pieces with a sledgehammer, in protest after he had been beaten for idleness. The legend itself is difficult to trace, first appearing in print in *The Nottingham Review* on the twentieth of December, 1811, with little independent corroboration. But validity is not a predicate of myth. And it didn't take long for the Luddite movement to spread to Yorkshire, Lancashire and beyond. Around five miles out from the centre of Manchester, from Monday the twenty-first to Tuesday the twenty-second of April, 1812, a gathering of Luddites besieged the Daniel Burton & Sons Mill in Middleton, burning down the house of the owner, Emanuel Burton, as *The Leeds Mercury* later reported.

... consisting of from one to two hundred, some of them armed with muskets with fixed bayonets, and

others with colliers' picks, who marched into the village in procession, and joined the rioters. At the head of the armed banditti a man of straw was carried, representing the renowned General Ludd whose standard bearer waved a sort of red flag.

The attack was later estimated to have accumulated some three-thousand Luddites into its number. What transpired from the chaos led Burton himself to have the mill barricaded, arming those workers who had remained loyal with muskets, who at first, in that seemingly common tactic, fired blanks into the crowd from the windows. When this proved to no effect, the weapons were loaded. At least five were killed on the spot, and some eighteen more injured, a precursor to the later Peterloo Massacre of the sixteenth of August 1819, in Saint Peter's Field.

Peterloo, that charge of armed cavalry into sixty-thousand peaceful protestors, has been memorialised variously in the 2018 Mike Leigh film of the same name, and in a controversially tepid monument of circular plinths on Windmill Street. Not strictly a Luddite gathering, but a working class one, the massacre was the subject of Percy Bysshe Shelley's infamous ballad, *The Masque of Anarchy*, written the same year. It was composed by Percy while residing with Mary in Italy, evident from the confusingly sleepy first lines.

As I lay asleep in Italy
There came a voice from over the Sea
And with great power it forth led me
To walk in the visions of Poesy.

And moving swiftly onto images of blood, revolution, and violent iconography, this call-to-arms against the oppressive classes culminates in its final stanzas. Shelley is sometimes hard to pin down as a revolutionary, certainly as a Luddite. As in William Blake's *The Marriage of Heaven and Hell*, of 1798, where Milton is found to be sympathising with the same Devil of *Paradise Lost* he seemingly abhorred, it sometimes seems Shelley is only half on the side of the workers, half enraptured with the sheer spectacle of power. This contradiction seethes under the surface of the poem's rising lions and fallen chains.

Rise like Lions after slumber
In unvanquishable number,
Shake your chains to earth like dew
Which in sleep had fallen on you —
Ye are many — they are few.

Either way, Shelley was late. As early as the time of the Frame Breaking Act of 1812, which made industrial sabotage a capital offence, Lord Byron was weighing in on the scene, for which fifty guinea rewards were being granted to

informers against luddites, should the courts bring a conviction. As well as composing his *Ode to The Framers of The Frame Bill*, Byron gave a speech before the lords in parliament earlier the same year.

But suppose it past,—suppose one of these men, as I have seen them meagre with famine, sullen with despair, careless of a life which your lordships are perhaps about to value at something less than the price of a stocking-frame; suppose this man surrounded by those children for whom he is unable to procure bread at the hazard of his existence, about to be torn for ever from a family which he lately supported in peaceful industry, and which it is not his fault than he can no longer so support; suppose this man—and there are ten thousand such from whom you may select your victims,—dragged into court to be tried for this new offence, by this new law,—still there are two things wanting to convict and condemn him, and these are, in my opinion, twelve butchers for a jury, and a Jefferies for a judge!

When Charles Dickens published *Hard Times* some forty later, in 1854, the grim factories and mills of Coketown, an amalgamation of Preston, Manchester and other industrial locales in between, had already become a concrete and seemingly unmoveable reality. One that had become the source of metaphysical contemplation, as Dickens muses on in a particularly finely-constructed sentence in the novel.

Set anywhere, side by side, the work of God and the work of man; and the former, even though it be a troop of Hands of very small account, will gain in dignity from the comparison.

This is the milieu from which Marxism evolved. In 1842, sent to oversee industrial work by his father in a hope to straighten out his radical ideals, Friedrich Engels famously arrived in England, settling in Manchester. For thirty years, briefly interrupted, Engels lodged at various addresses, including 6 Thorncliffe Road, 25 Dover Street and 58 Dover Street, all in Chorlton-on-Medlock. Three years after his arrival, he published his chef d'oeuvre, not to be translated from the German until the turn-of-the-century, as *The Condition of The Working Class in England*.

By this time, the Luddite movement had shifted from focus, many members executed, or shipped out as convicts to the penal colonies in Australia, the uprisings dwindling-to-none by the eighteen-twenties. What had once been a cause that had brought England the closest it had been to popular revolution since the sixteen-hundreds, a formidable troupe, thorny to infiltrate with their vows of silence and common workplaces, had virtually disappeared. Little had fundamentally changed, and it's tempting to see the Luddite struggle as noble but vainglorious. But Engels had much to say in *The Condition of The Working Class in England* of the degradation that continued in industrial Mancunia.

In a rather deep hole, in a curve of the Medlock and surrounded on all four sides by tall factories and high embankments, covered with buildings, stand two groups of about 200 cottages, built chiefly back to back, in which live about 4,000 human beings, most of them Irish. The cottages are old, dirty, and of the smallest sort, the streets uneven, fallen into ruts and in part without drains or pavement; masses of refuse, offal, and sickening filth lie among standing pools in all directions.

At its height, my Neoluddite fixation was strong enough that I chose to avoid all modern technology as far as possible. This being a neurotic obsession, it was impossible to achieve in full, instead I began to avoid basic appliances. Laptops. Light-switches. Buses. Microwaves. Phones. It would have been a compulsion if it wasn't contrived with such ascetic logic. I cut up political magazines and made militant photo-collages, some which were hidden away in an adolescent drawer. One evening my twelve-year-old brother had offered me the TV remote. I smacked his hand away. This was the first and final time I ever showed him violence.

I had been inspired by the protests that had taken place across the country, attended by thousands. Students, teenagers, others like me, who took to the streets against the betrayal of the Conservative-Liberal Democrat coalition in their pledge not to raise university tuition fees or cut

funding to education. We walked out of our colleges, schools, universities, marched through the streets of Manchester in the winter cold, scoffing at the stands set up by the Socialist Worker in All Saints Park, who couldn't help but seem out-of-touch.

When we hustled under a brick railway arch in Deansgate, into that darkness, our faces against one-another's backs, the air-horns breaking over the murmuring of thousands, and the red flare burst out ahead of us, leading us into the light where yuppies held banners of support from the glass-bordered balconies of their towering apartments, it seemed that the masses could really make a difference. For a moment, it was not Luddism that mattered, but freedom, youth, resistance.

We attended talks at the university. Some people I knew were thrown out sheepishly by the student coordinators, after lighting a joint in the lecture hall of the Simon Building. I was embarrassed. A schoolboy gave a moving speech about how revolution could happen. How we, the young, could bring it about. He looked tough, his hair shaved, and spoke with great charisma. On the brief train home, he sat next to me. No one spoke. Then he asked me if he was getting off at the right stop.

I attended more protests in the city centre, demonstrations against fracking and other forms of environmental exploitation, long after they had lost their trendy appeal,

when no one I knew turned up. On one, the group of several hundred sat down at crossroads on Princess Street. The traffic temporarily came to a halt. The group stayed that way for around five minutes, then they got up, the police following them, strolling along, seeming strict but fairly bored. The experience, overall, was one not of empowerment, but of bad humility.

Principal results from the experiments are as follows: (1) Global warming to the level attained at the peak of the current interglacial and the previous interglacial occurs in all three scenarios; however, there are dramatic differences in the levels of future warming, depending on trace gas growth. (2) The greenhouse warming should be clearly identifiable in the 1990s; the global warming within the next several years is predicted to reach and maintain a level at least three standard deviations above the climatology of the 1950s.

In 1988, official evidence of climate change was presented to the US congress by Professor James Hansen of NASA, who explained his rigorous findings that afternoon in June the same year. He estimated its effects would be visible by the nineties, and notably, that they were human-made. Hansen later claimed that there had been attempts by administrators at NASA to alter the report of his findings, to reduce their severity, their potential impact. In 2011, he and more than one-thousand other protestors were arrested after demonstrating in front of the White House. Along with

Robert F. Kennedy Junior, nephew of the eponymous former-president, Hansen was arrested again in 2013. On both occasions, he had been protesting the expansion of the Keystone XL Pipeline through Canada and America.

To sabotage a factory, a chemical-plant, a drill-site: overwhelmed, I could only imagine that reality. At school, I had won the annual history prize two-years running, and had taken it deeply into my thoughts when the history teacher, Ms. W, had explained the duplicity of the terrorist and the freedom fighter. I ferried away little strands of magnesium from the chemistry department, researched methods to construct impromptu napalm, ways of industrial sabotage. But it was a meek exercise with no absolute objective.

Actual happiness always looks pretty squalid in comparison with the overcompensations for misery. And, of course, stability isn't nearly so spectacular as instability. And being contented has none of the glamour of a good fight against misfortune, none of the picturesqueness of a struggle with temptation, or a fatal overthrow by passion or doubt. Happiness is never grand.

At my black-painted teenage desk, I put Huxley's *Brave New World* carefully down. In those days, if I had found others like me, others who felt the thin boundary between *idée fixe* and longing for an actual radical restructure,

perhaps those times would have been different. The root of the will to overcome the immense operations of exploitation was there, in the young and in the old, but it lacked direction, desperation. The Luddites of the nineteenth-century were fighting for their livelihoods, their freedoms. It's a sad truth that necessary resistance is an abstraction to those who don't see the limitations growing on their liberty. There are reasons to lean towards Luddism, to resist technological advancement, transparent enough to draw together a movement. But I had already turned inwards. In those shadows, there are countless other figures, turning and turning around.

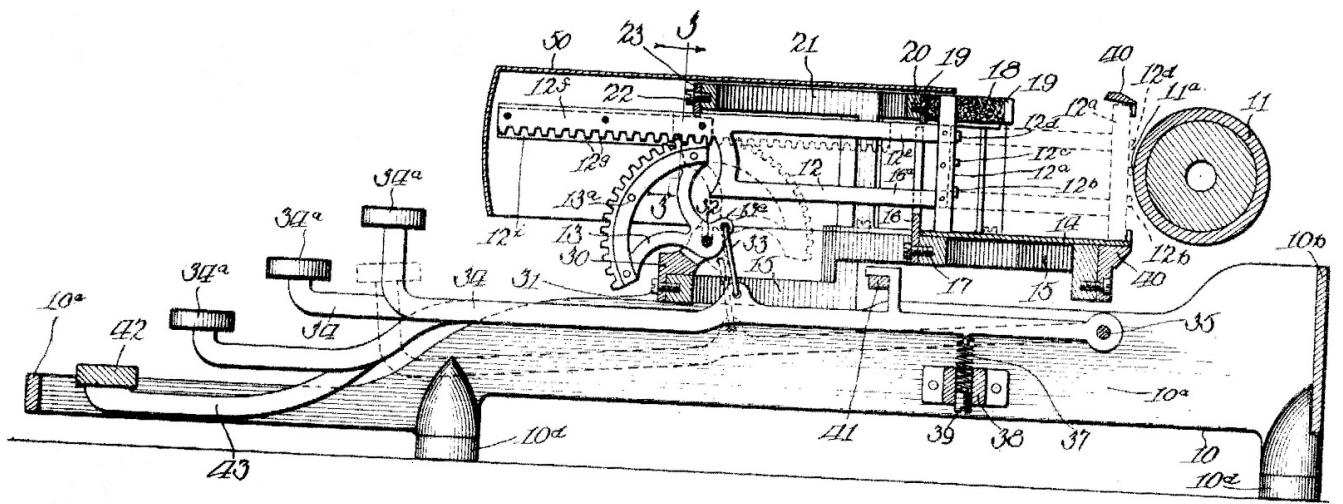

About fifty assembled... they smashed through the gates and started to break windows in the mill, led by two young women, Mary Molyneux, 19, and her sister Lydia, 15, who were seen, according to court papers, “with Muck Hooks and coal Picks in their hands breaking the windows of the building”... shouting “Now Lads” to encourage the men on. With the windows broken, men took straw from the stables and set a series of fires inside: “The whole of the Building,” wrote the Annual Register correspondent, “with its valuable machinery, cambrics, &c, were entirely destroyed.”

Spring, Black Moon

FORGED.noblogs.org